

# Negative Airlift System

## The Most Sanitary Solution on the Market

Proper sanitation and efficient maintenance are essential to your company's success. Consumers require a safe and consistent final product while you need a system with minimal downtime and product loss for profitability. The Horizon Systems Negative Airlift System ensures both. It's engineered to protect product shapes and sizes while minimizing the risk of post-processing contamination when conveying product from the extruder to the dryer. Component configurations can include purified air to preserve sanitation after the kill step, as well as additional air treatments like ozone.

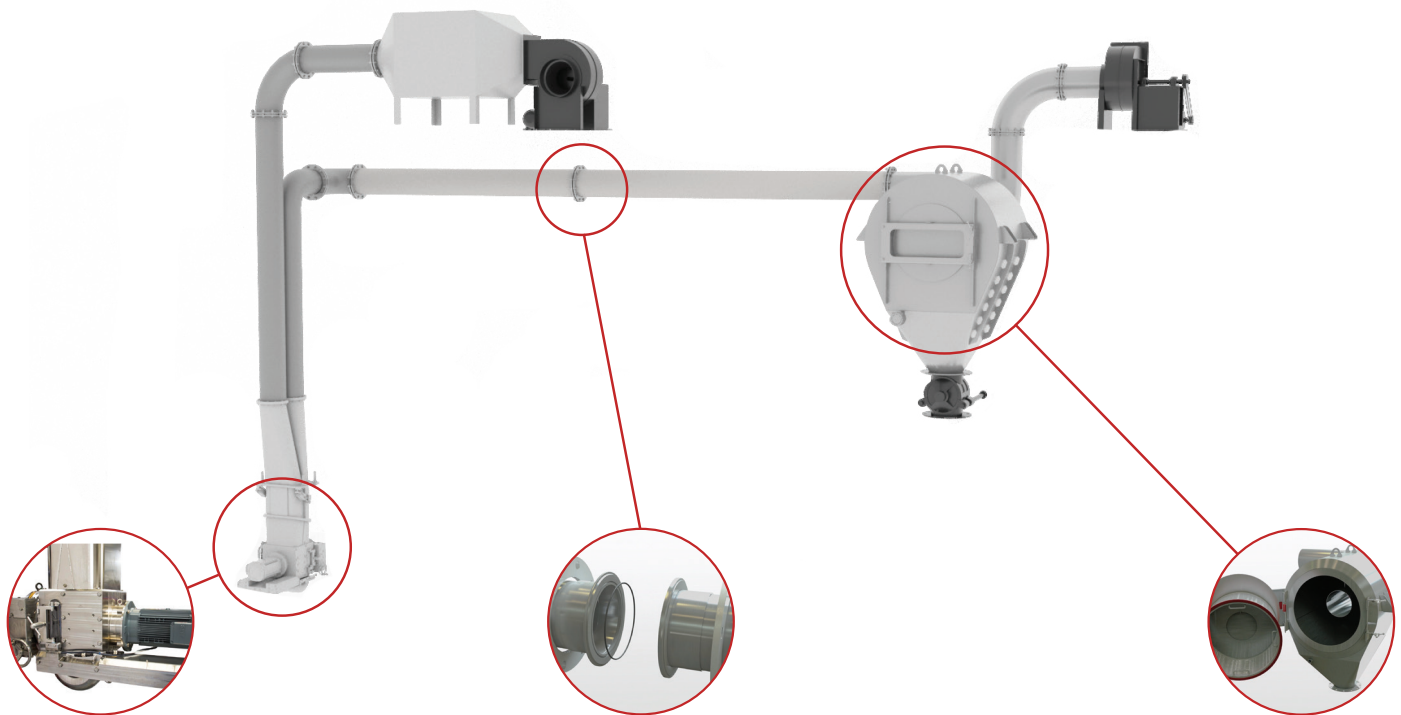

### Frazer-Nash Sanitary Extruder Hood

We've partnered with Frazer-Nash Manufacturing to offer their best-in-class extruder hood as an option with our Negative Airlift System.

- With minimal maintenance costs, minimal kibble and fines loss, and less downtime, the Frazer-Nash extruder hood is more affordable than other hoods over a three year period.
- Toolless access, no required floor support, exceptional all-around access, and no alignment issues make it easy to use.
- Air divert allows high temperature bake out, plus easy cleanout and an all-stainless construction add to its exceptional sanitation.



### Metal-to-Metal Compression Coupling

Horizon Systems' machined metal-to-metal compression couplings ensure consistent product flow and prevent buildup that can negatively affect sanitization.

- Metal-to-metal couplings are machine tight and gasket features die-cut teeth that eliminate internal ledges that can cause product degradation.
- Equal pressure is applied to the entire surface area of the inner sleeve and gasket without affecting thin-wall pipe or tubing.

### Kleen Horizontal Product Separator

A low-profile alternative to traditional cyclone collectors, the Horizon Systems Kleen Horizontal Product Separator is ideally suited for a wide range of installations.

- Easy access for inspection, cleaning and sanitization through a large tool-free door.
- A silicone U-channel gasket door seal provides broad heat and chemical compatibility.
- Sanitary fitting allows for mounting high level probe/plug indicators.

